

L410 UVP - E20

2022

The L 410 is an all-metal, high-wing turboprop aircraft that is exceptionally reliable and safe to operate even in extreme climatic conditions. It is used in more than 60 countries across five continents, with the majority operating in Russia, followed by Africa, Southeast Asia, South America and Europe.

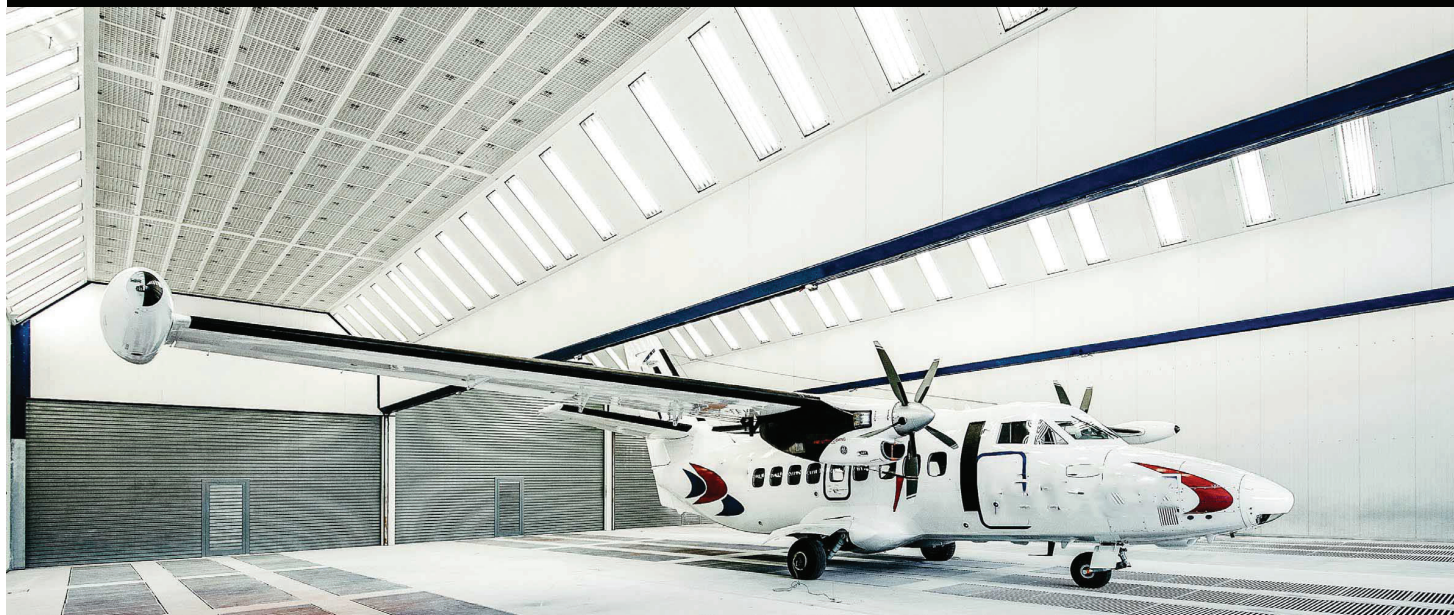

Your Aircraft Sales Team

Gavin Kiggen

President, Aircraft Sales & Acquisitions
M. + 27 82 419 1067
gavin.kiggen@luxaviation.com

Pierre du Plessis

Director, Aircraft Sales & Acquisitions
M. +27 82 314 8106
pierre.duplessis@luxaviation.com

Bronwen Meyer

Sales Associate & Administration - Aircraft Sales & Acquisitions
M. +27 72 496 2299
bronwen.meyer@luxaviation.com

Jake Giovannoni

Sales Associate - Aircraft Sales & Acquisitions
M. +27 82 513 9604
jake.giovannoni@luxaviation.com

Specifications and/or descriptions are provided as introductory information only and do not constitute representations or warranties. Verification of specifications remain the sole responsibility of purchaser. Photographs and images may have been modified to remove logos, registration marks, or other identifying information to protect the privacy of the aircraft's current owner. The aircraft is subject to prior sale, lease, and/or removal from the market without prior notice.

Airframe

Operating hours since entering service 26 hours and 15 minutes

Engines

GE H80-200 GE Aviation Czech s.r.o

Take-off Performance	597 kW / 800 SHP
TBO	3 600 – 4 000 FH
Empty Weight	201 kg / 447 lb

Propellers

AV-725 Avia Propeller s.r.o., Czech Republic

Propeller speed	1 950 RPM
TBO	3 600 – 6 600 FH
Weight	88 kg / 207 lb

Speed

Maximum Cruise Speed	405 km/h	219 KTAS
Maximum Range	1 500 km	810 NM
Maximum Endurance	5,1 h	306 min
Maximum Operating Altitude	4.200m	14.000ft
One Engine Inoperative Ceiling	4.755m	15.600ft
Service Ceiling	8.382m	27.500ft
* 45 minutes reserve		

Rates

Rate of Climb	8,5 m/s	1 673 fpm
Rate of Climb One Engine Inoperative	1,8 m/s	354 fpm
Take-off Distance Required (TODR)	510 m	1 673 ft
Landing Distance Required (LDR)	500 m	1 604 ft

Cabin Volumes

Passenger Cabin Volume	17,9 m ³	632 ft ³
Passenger Door	0,8 x 1,46 m	31,5 x 57,5 in
Cargo Door	1,25 x 1,46 m	49,2 x 57,5 in
Seat Pitch	0,76 m	29,9 in
Baggage Compartment Capacity	1,47 m ³	51,9 ft ³

Weight

Maximum Take-off Weight	6 600 kg	14 550 lb
Maximum Landing Weight	6 400 kg	14 109 lb
Maximum Zero Fuel Weight	6 000 kg	13 228 lb
Maximum Payload	1 800 kg	3 968 lb
Maximum Usable Fuel	1 300 kg	2 866 lb

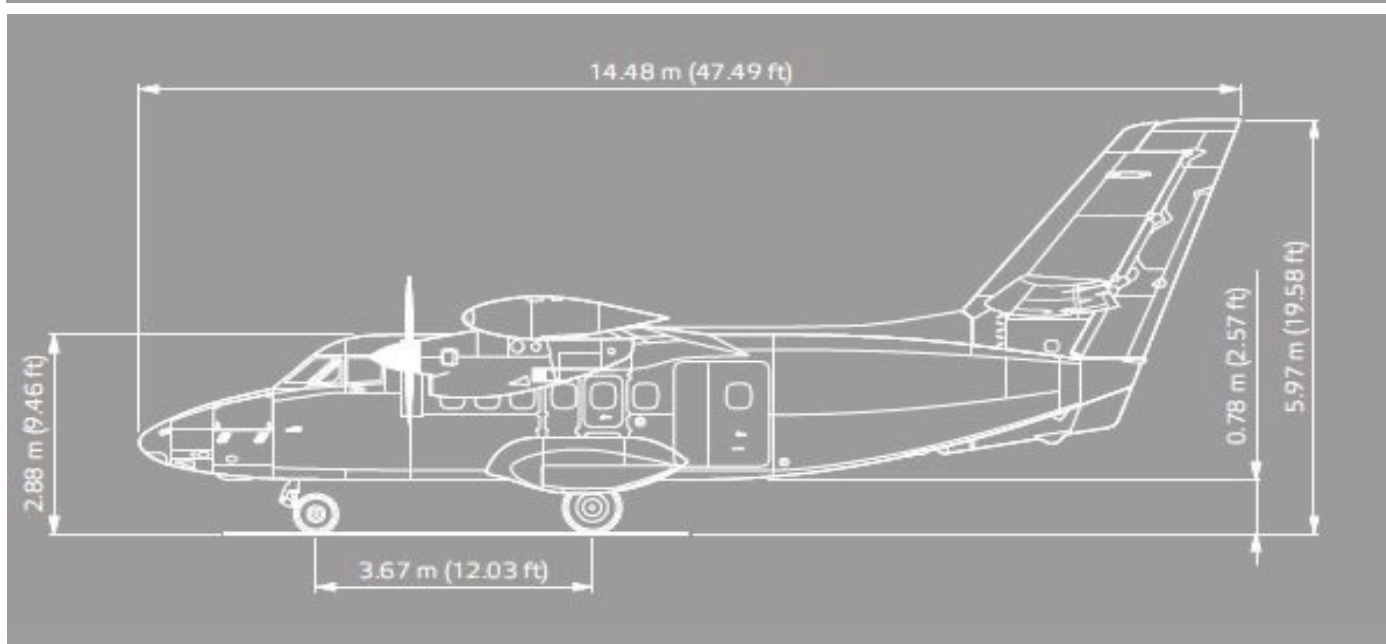
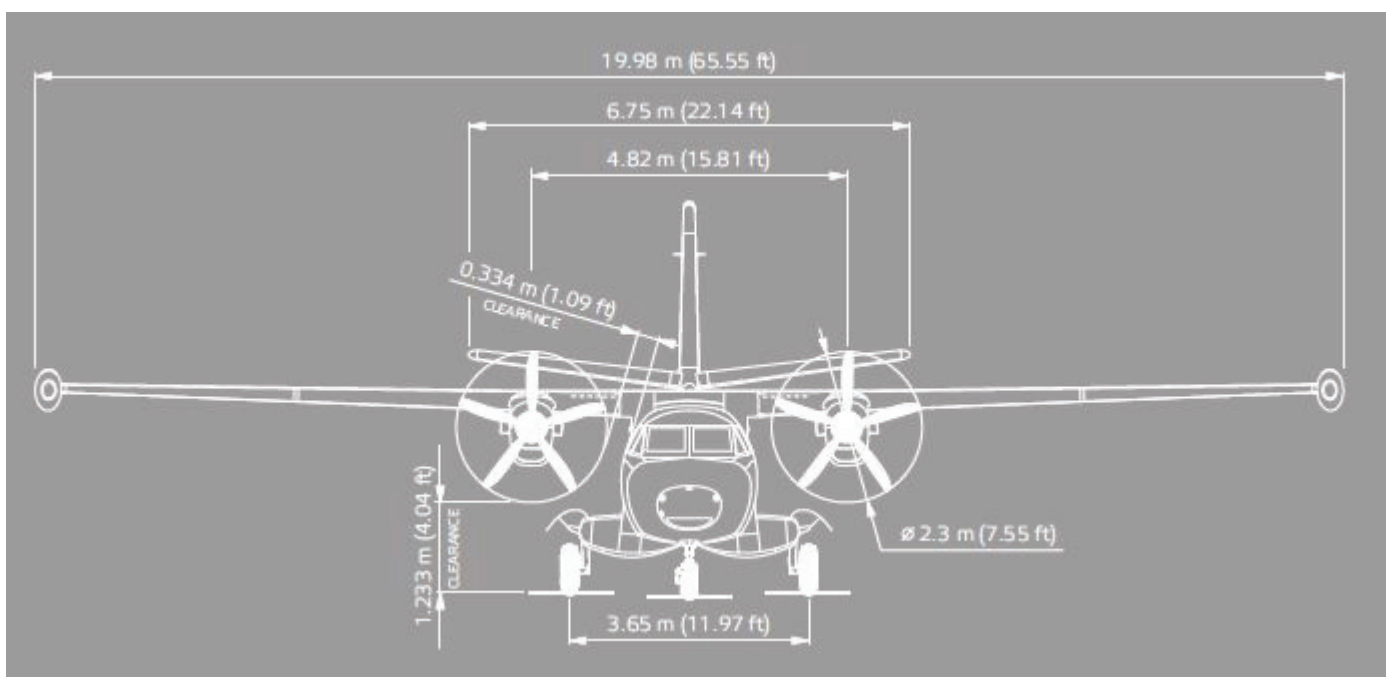



Your Aircraft Sales Team

Gavin Kiggen

President, Aircraft Sales & Acquisitions
 M. + 27 82 419 1067
gavin.kiggen@luxaviation.com

Pierre du Plessis

Director - Aircraft Sales & Acquisitions
 M. + 27 82 314 8106
pierre.duplessis@luxaviation.com

Bronwen Meyer

Sales Associate & Administrator - Aircraft Sales & Acquisitions
 M. + 27 72 496 2299
bronwen.meyer@luxaviation.com

Jake Giovannoni

Sales Associate - Aircraft Sales & Acquisitions
 M. + 27 82 513 9604
jake.giovannoni@luxaviation.com

Specifications and/or descriptions are provided as introductory information only and do not constitute representations or warranties. Verification of specifications remain the sole responsibility of purchaser. Photographs and images may have been modified to remove logos, registration marks, or other identifying information to protect the privacy of the aircraft's current owner. The aircraft is subject to prior sale, lease, and/or removal from the market without prior notice.